

User's Manual

CITIZEN **MOBILE THERMAL PRINTER** **MODEL CMP-10**

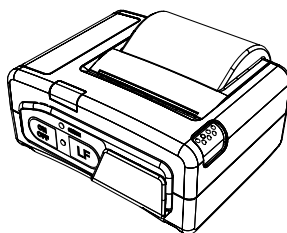

Japan CBM Corporation

FCC Declaration of Conformity

We, the Responsible Party : CBM America Corporation
363 Van Ness Way
Suite 404
Torrance, CA 90501, U.S.A
Telephone (310) 781 1460

declares that the product:

Trade Name : Japan CBM Corporation
Product Name : Mobile Printer
Model Number : CMP-10

confirms to the following specifications:

Regulation : FCC Part 15B, Class B
Test Method : ANSI C63.4-1992

and therefore is in compliance with the protection requirement of FCC Rules relating to electromagnetic compatibility.

issued on August 2002

Authorized Signature:



Toru Morimoto
President

Compliance Statements

FCC Compliance Statement for American Users

This equipment has been tested and found to comply with the limits for a Class B digital device, pursuant to Part 15 of the FCC Rules. These limits are designed to provide reasonable protection against harmful interference in a residential installation. This equipment generates, uses, and can radiate radio frequency energy and, if not installed and used in accordance with the instructions, may cause harmful interference to radio communications. However, there is no guarantee that interference will not occur in a particular installation. If this equipment does cause interference to radio or television reception, which can be determined by turning the equipment off and on, the user is encouraged to try to correct the interference by one or more of the following measures:

- Reorient or relocate the receiving antenna.
- Increase the separation between the equipment and receiver.
- Connect the equipment into an outlet on a circuit different from that to which receiver is connected.
- Consult the dealer or an experienced radio/TV technician for help.

CAUTION: Use shielded cables to connect this device to computers.

Any changes or modifications not expressly approved by the grantee of this device could void the user's authority to operate the equipment.

EMI Compliance Statement for Canadian Users

- This Class B digital apparatus complies with Canadian ICES-003.
- Cet appareil numérique de la classe B est conforme à la norme NMB-003 du Canada.

CE Declaration of Conformity

Manufacturer's Name : Japan CBM Corporation
Manufacturer's Address : CBM Bldg., 5-68-10, Nakano, Nakano-ku
Tokyo, 164-0001, Japan

Declaration on the Product

Product Name : Mobile Printer
Model Number(s) : CMP-10
(S. No. 0270001 ~)

Conforms with the Following Standards

LVD : EN60950 : A4: 1997, A11: 1997
EMC : EN55022 : 1994 Class B
: EN61000-3-2 : 1995+A1: 1998+A2: 1998+A14: 20α
: EN61000-3-3 : 1995
: EN55024 : 1998

Supplementary Information

"The product complies with the requirements of the Low Voltage Directive 73/23/EEC, 93/68/EEC and the EMC Directive 89/336/EEC, 92/31/EEC, 93/68EEC."

Place : Tokyo, Japan

Signature

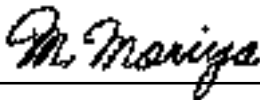

Date : August, 2002

Full Name : Mikio Moriya
Position : General Manager
R & D Department

European Contact:

CBM Europe
Narzissenweg 2 a
D-21502 Geesthacht, GERMANY

This declaration is applied only for 230 V model.

GENERAL PRECAUTIONS

- Before using this product, be sure to read through this manual. After having read this manual, keep it in a safe, readily accessible place for future reference.
- The information contained herein is subject to change without prior notice.
- Reproduction or transfer of part or all of this document in any means is prohibited without permission from CBM.
- Note that CBM is not responsible for any operation results regardless of missing, error, or misprinting in this manual.
- Note that CBM is not responsible for any trouble caused as a result of using options or consumables that are not specified in this manual.
- Except explained elsewhere in this manual, do not attempt to service, disassemble or repair this product.
- Note that CBM is not responsible for any damage attributable to incorrect operation/handling or improper operating environments which are not specified in this manual.
- Data are basically for temporary use, not stored for a long period or permanently. Please note that CBM is not responsible for damage or lost profit resulting from the loss of data caused by accidents, repairs, tests or other occurrence.
- If you find loss of information, error, or uncertain matter, please contact your CBM dealer.
- If you find any disordered or missing page (s), contact you CBM dealer for replacement.



Company names and product names in this manual are trademarks or registered trademarks of relevant companies.

Copyright © 2002 Japan CBM Corporation

SAFETY PRECAUTIONS

About Pictogram

Precautions and notices necessary to follow for preventing hazards to the user or other person or their properties are defined as shown below. Hazards and degrees of damage that may be caused by ignoring the instructions are categorized as shown below. Please be familiar with the content of these definitions before reading this manual.

 Danger	Indicates the case that may result in death or serious injury.
 Warning	This symbol indicates that using the product improperly in defiance of this symbol may result in death or serious injury.
 Caution	This symbol indicates that using the product improperly in defiance of this symbol may result in injury or damage to properties.

Definition of Pictogram



This symbol indicates the hazard that needs precautions.



This symbol indicates prohibited actions.



This symbol indicates mandatory actions.

Precautions in Handling Printer



WARNING



- If the product is kept in use under abnormal condition such as generation of heat, smoke, or abnormal odor, a fire may occur. Immediately turn the printer power off, remove the battery, and contact our service agent.



- If any foreign matter (metal tip, water, liquid) enters the product, immediately turn the printer power OFF, remove the battery, and contact our service agent. Ignoring this instruction may result in a fire.



CAUTION



- Do not place the printer on a shaky table or other unbalanced place. The printer may drop or fall resulting in injury.
- Avoid using or storing in the following place. Damage to printer may be caused.
 - In a car parked in a sunny place, a place exposed to direct sunlight, near heat generating equipment, or the like.
 - A place where temperature or humidity is excessively high or low, or its change is radical.
 - A dusty place.
 - A place likely to get a splash of water or liquid.
- Never drop nor give strong shock or vibration. Fault or damage may be caused.
- Avoid entry of foreign material. Otherwise, fault may occur.
- Do not use volatile liquid (thinner, benzene, etc.) or wet cloth when cleaning the printer. Deterioration or discoloration may occur. Use a dry, soft cloth for cleaning.
- Do not move the printer or give any shock or vibration to it while the printer is in operation or in standby operation. The printer power may be disconnected and the print data may be lost.

Precautions on Using Printer



WARNING



- Do not touch the print head or paper cutter while replacing print paper. Heated print head may cause burn. The cutter may cause injury to the hand.



CAUTION



- Use of print paper other than specified may result in not only deteriorated print quality but shortened life of print head (printing portion).



- Do not tap or rub the print head with edged or hard material.
- When dew condensation is present on the print head, dry it completely before printing. Printing with dew condensation may damage the print head.
- Do not use the battery other than specified.

Precautions on Using Battery



DANGER



- Entering battery liquid may result in loss of eyesight. Immediately wash eyes with fresh water and get medical care.
- Keep the following in mind when handling battery. Otherwise, liquid leakage, heat generation, and explosion may result.
 - Do not throw battery into fire or do not apply heat.
 - Do not peel or scratch the external tube.
 - Soldering is prohibited.
 - Do not give strong shock to battery or throw it away.
 - Do not short-circuit the positive and negative terminals with a metal such as metal wire.
- Never disassemble or modify battery. Otherwise, liquid leakage, heat generation, or explosion may occur.



WARNING



- If battery liquid attaches to skin or cloth, immediately wash it out with fresh water. Otherwise, skin disorder may be caused.



CAUTION



- Do not dip battery in water or sea water. Wet battery may generate heat or may be subject to corrosion.

- Do not use or leave battery at high temperature. Using or leaving battery in a place of high temperature may result in liquid leakage, deteriorated performance, or shortened lifetime.



- Keep battery beyond the reach of a baby or child. Pay attention not to let a child take out the battery.

- If the battery is used for the first time, be sure to charge it completely before use.

- If any abnormality is found while the battery is in use, stop the operation and carry the battery in local sales agent.

- The battery in the printer is shipped partially charged. Please fully charge the battery prior to using the printer.

Carry used battery in recycling agent.

Precautions on Setting Print Paper



CAUTION



- Before printing, confirm that print paper is set straight forward at the exit from the print (thermal) head. Skewed setting may result in paper jamming.

- To prevent skewed insertion of paper, use the following form for the end of paper.

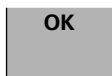

Precautions on Using Thermal Paper (Print Paper)



CAUTION



- Print density may change with the kind of print paper. Print density is adjusted by the Print Density Set command in Command Reference. For details, refer to Command Reference (Separate sheets).
- Observe the following when using thermal paper. Thermal paper is not resistant to discoloration, deterioration in quality, and thin printing.
 - Do not let printed thermal paper exposed to light for a long time.
 - Avoid exposure to high temperature, humidity, liquid, or sunlight.
 - When keeping the printer thermal paper on a board, do not use paste, adhesive, or adhesive tape containing volatile organic solvent.
 - For long-time storage, use thermal paper of high storage type or copy it with plain paper copier.
 - Avoid contact with a film of vinyl chloride for a long time.
 - Avoid using ammonia. Do not put thermal paper near the paper copied by use of ammonia.
 - Avoid putting sweat or grease from your hands on the surface (printed or to be printed) of thermal paper.
 - Store thermal paper in a dark place with average temperature below 25°C and relative humidity below 65% .
- Using print paper with a thickness outside the recommended range may cause improper print quality.

Precautions on Using Special Serial Cable



WARNING



- With one side of the connector connected to this product, do not touch the metal part of the other connector.



CAUTION



- Static electricity may cause breakdown of internal circuit of this product.
- Do not leave this product with a cable wound around it for a long time. Disconnection or discoloration may result.
- Plugging and unplugging the connector shall be done securely in the correct direction.

Precautions on Using AC Adapter



CAUTION



- Do not use the product at a voltage and frequency other than specified.
- Do not use AC adapter other than specified.



- Before use, confirm that the power receptacle has sufficient capacity.
- Do not connect to the power receptacle where multiple connections are used.
- Do not step on, tap, or put any object, on the cable of the AC adapter.
- Before connecting or disconnecting AC adapter, turn the printer power OFF. Do the operation securely.

THE TABLE OF CONTENTS

1. INTRODUCTION	10
1.1 Features	10
1.2 Included and Optional Accessories	11
1.3 Type Classification	11
2. GENERAL SPECIFICATIONS	12
3. EXPLANATION OF PRINTER PARTS	15
3.1 LED Indicators	15
3.2 Communication Port and Switch	16
3.3 Inside of Paper Cover	17
3.4 Buzzer	17
3.5 Bottom Surface and Battery Cover	18
3.6 Dimensions and Views	19
4. OPERATION	20
4.1 Replacing the Paper Roll	20
4.2 Method of Charging	21
4.3 Communication by IrDA	22
4.4 Communication Via Serial Port (Cable)	23
4.5 Reading Mag Stripe Card (Only Model with Built-in Mag Stripe Card Reader)	24
4.6 Removing the Battery Pack	25
4.7 Installing the Battery Pack	26
5. FUNCTION	27
5.1 Auto Power OFF	27
5.2 Interface Selection	27
5.3 Low Battery Detection	27
5.4 Monitoring the Print Head Overheating	28
5.5 Self Testing and Internal Settings	28
5.6 Print Area	28
6. LIST OF COMMANDS	29
7. MAINTENANCE AND SERVICE	31
8. APPENDIX HANDLING BELT CLIP KIT	32
8.1 How to Mount Belt Clip	32
8.2 Mounting Rubber Feet	32

1. INTRODUCTION

CMP-10 is a compact, full featured portable line thermal printer, which can be used in a large variety of job environments ranging from door-to-door sales through small and mid-sized catering establishments, car-rentals, parking lots, field services to on-board sales on land, sea and air.

IrDA communication with a PDA or similar device is useful for business activities at the point of sale or service.

Easily worn on the belt it is a highly efficient device for printing plain text and graphic receipts on demand plus logos, bar codes and other graphic elements.

1.1 Features

- Small and lightweight.
- High speed and low noise emission of the line thermal printing mechanism.
- Long-life printing head with high reliability.
- Easy paper-handling, owing to the paper-drop-in style.
- The large-capacity Lithium-ion rechargeable allows an extensive amount of printing with a single charge.
- Built-in IrDA.
- Built-in mag stripe card reader. (Option)
- Choice of paper-roll diameters – Max. 40 or 50 mm.

1.2 Included and Optional Accessories

When unpacking the package, confirm the availability of:

- Printer unit: 1 piece
- Sample paper roll: 1 roll
- AC adapter: 1 piece
- User's manual: 1 copy

E (European) model

- Belt clip kit 1 set
(Belt clip, 2 × screws, 2 × rubber feet)

Please refer to the Appendix for how to mount belt clip and rubber feet.

U (North America) model

- Mask sheet for screw hole

If you remove belt clip, it is recommended that the mask sheet for screw hole supplied be attached to the square frame for belt clip to prevent entry of foreign substance into the screw hole.

- Serial cable

Optional Accessory for E model: Serial Cable CA10-01

1.3 Type Classification

Classified by the following designation.

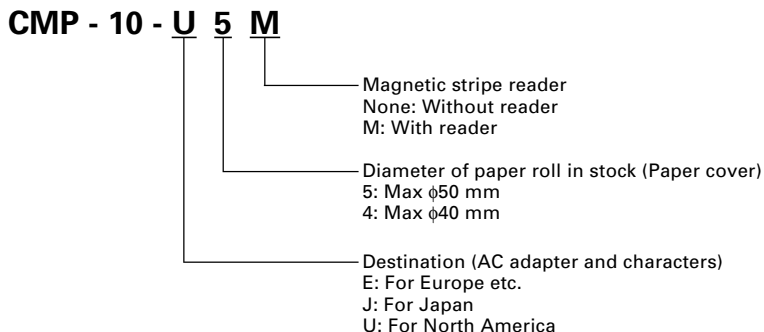

This user's manual is compiled for E/U destination model.

2. GENERAL SPECIFICATIONS

Feature	Parameters
Printing system	Direct thermal printing
Printing speed	50 mm/sec
Printing head	Total dots: 384 Dot density: 8 dots/mm Printing width: 48 mm
Emulation	ESC/POS commands plus extra commands for specific printer features
Characters	ASCII Code, Alphanumeric characters, International characters, Windows Code page
Characters per line	FONT A: 32 characters/line, FONT B: 42 characters/line
Dot matrix	FONT A: 12H × 24V, FONT B: 19H × 16V
Bar code type	UPC-A/E, JAN(EAN)13/8 columns, ITF, CODE39, CODE128, CODABAR, CODE93
Paper feed system	Friction feed
Paper width	58 ±0.5 mm
Paper thickness	60 - 65 μm
Recommended paper	TF50-KS-E2D (Nippon Paper)
Paper roll maximum diameter	40 mm (CMP-10-×4), 50 mm (CMP-10-×5)
Minimum core diameter	8 mm
Interfaces	IrDA version 1.0 Serial interface (by serial cable - option)
IrDA Interface	Mode: Infrared transceiver mode Transport wave: Wave length - 850 to 900 nm Communication speed: 9600, 19200, 38400, 57600, 115200 bps Data length: 8 bits Start bit: 1 bit Stop bit: 1 bit Parity: none Communication: Half duplex Flow control: IrDA standard Communication distance: Max. 80 cm

Feature	Parameters
Serial interface	Speed: 1200, 2400, 4800, 9600, 19200, 57600, 115200 bps Interface: Bidirectional serial communication Signal level: RS-232C Data length: 8 bits Start bit: 1 bit Stop bit: 1 bit Parity: None Flow control: Xon/Xoff Connector: Motorola Star Tac
Input buffer	64 KB
Mag stripe reader	Track 1, 2, 3
LED color	Power LED: GREEN and RED Charge LED: GREEN and RED
Operation switches	Power switch 1, LF switch 1
Sensors and error monitoring	Paper end sensor, Open cover sensor, Head temperature, Low battery
Power consumption	Idle - approximately 2W When printing - approximately 15W
Battery	Battery type: Li-ion battery pack Cell Voltage: 3.7 V Number of cells: 2 Battery pack voltage: 7.4 V Battery pack capacity: 2000 mAh
Battery charging time	Approximately 3 hours by main unit + AC adapter
Maximum lines printed with fully charged battery	40,000 lines (At temperature 20°C, standard setting, alphanumeric slide pattern printing. The number of lines may be changed by such condition as temperature, etc.)
Power supply monitoring	Auto Power OFF (programmable - from 1 to 60 min.) Low battery monitoring included.
AC Adapter	Model: 10AD-JU (for Japan, USA, and Canada) 10AD-E (Europe) Input voltage 90 V - 264 V AC Output voltage 9.0 V DC 1.0 A
Operating Environment	Temperature: 5 – 40°C Humidity: 35 – 80% RH (No dew condensation)
Storage Environment	Temperature: –20 – 60°C Humidity: 10 – 90% RH (No dew condensation)

Feature	Parameters
Reliability	Print head: 100,000,000 pulses or 50km (Normal temperature, 12.5% density, rated energy) Mechanism: 15,000,000 lines
Safety standard and EMI	UL, C-UL, TUV, GS, CE Marking FCC Class B, VCCI Class B
Dimensions	116 (W) × 104 (D) × 63 (H) mm (50 mm paper cover + Mag stripe reader)
Weight	Approx. 370 g (with battery and belt clip without paper)
Options	Serial Cable, Mag Stripe card reader (Factory option)

3. EXPLANATION OF PRINTER PARTS

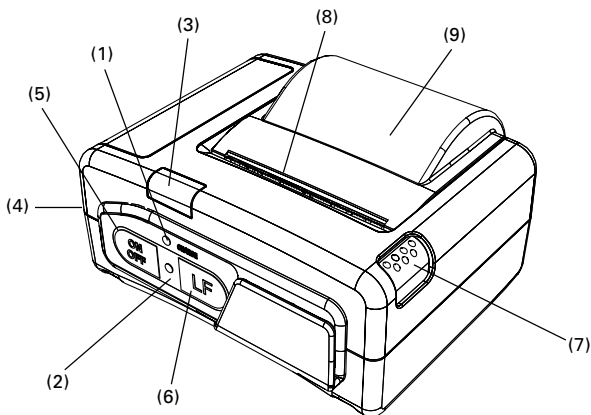

3.1 LED Indicators

- (1) Charge LED
RED on: Battery is charging
GREEN on: Battery is Fully charged
- (2) Power (Error) LED
GREEN on: Lights when printer is powered ON.
RED/GREEN blinks fast: No paper or cover open.
RED/GREEN blinks slow: Print head is overheated or macro is in process and awaiting LF switch operation.
Red on: Lights red under the following condition.
- When LF switch is pressed
 - When waiting for reading mag stripe card (When card reading is finished or after 10 seconds, it lights green.)
 - While pressing and holding the Power switch to turn the printer off (When releasing the switch after the LED changes to green, the printer power is turned OFF.)
- The LED will light red momentary at the time of IrDA communication.

3.2 Communication Port and Switch

- (3) IrDA interface unit
Receives data from host and transmits printer status.
For communication with IrDA communication, refer to 4.3.
- (4) Serial port
For serial cable (option) connection to host.
For the method of communication with cable and connecting cable, refer to 4.4.
- (5) Power switch (ON/OFF)
Press and hold the Power switch for 1 second to turn the printer power ON.
To turn OFF the printer, press and hold the Power switch till the Power LED changes from red to green.
- (6) Line feed switch (LF)
Press once for 1 line paper feed.
Press down and hold for continuous paper feed to any required length.
If print data still remains in the printer when printing is suspended due to no paper or the like, recover the printable condition and then press this switch to resume printing.
- (7) Open cover switch
Press down to open the paper cover (9) for replacing the paper roll.
- (8) Manual cutter
To cut the printed paper, gently pull the paper from the edge of the paper at the angle so that paper firmly contacts the manual cutter. Improper direction of pull may result in poor cutting or excessive unwinding of paper, or opening the cover. In some case, characters may be destroyed at the first printing after the paper is cut.
- (9) Paper cover
Set print paper inside this cover.

3.3 Inside of Paper Cover

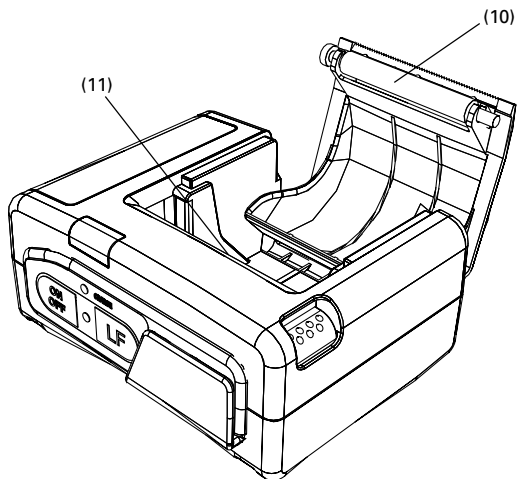

- (10) Paper feed roller
Feeds paper through the printing mechanism.
- (11) Printing (thermal) head
Records print data on the thermal paper.

3.4 Buzzer

The built-in buzzer sounds in the following cases.

When low battery is detected (sounds 3 times)

When magnetic card was successfully read (sounds once)

When buzzer command is sent (the number of sounding times is controllable)

3.5 Bottom Surface and Battery Cover

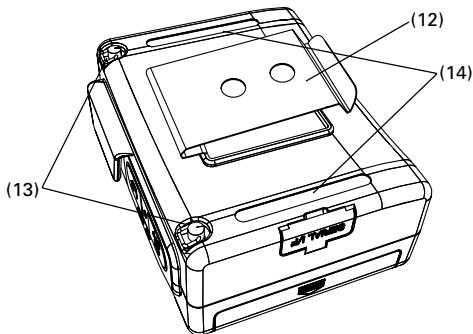

- (12) Belt clip
Attaches to the printer on your belt.
(Not installed at the time of shipment. To use the belt clip, please install the belt clip by yourself.)
- (13) Strap holder
Metals for holding a strap.
(The strap shall be prepared by the user.)
- (14) Groove for rubber foot
If you want to use rubber feet for stationary use, attach rubber feet here.

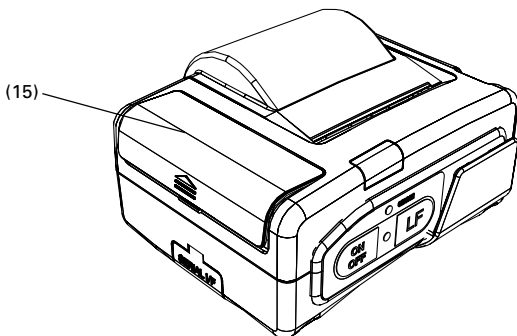

- (15) Battery cover
Cover of battery compartment

3.6 Dimensions and Views

(Unit: mm)

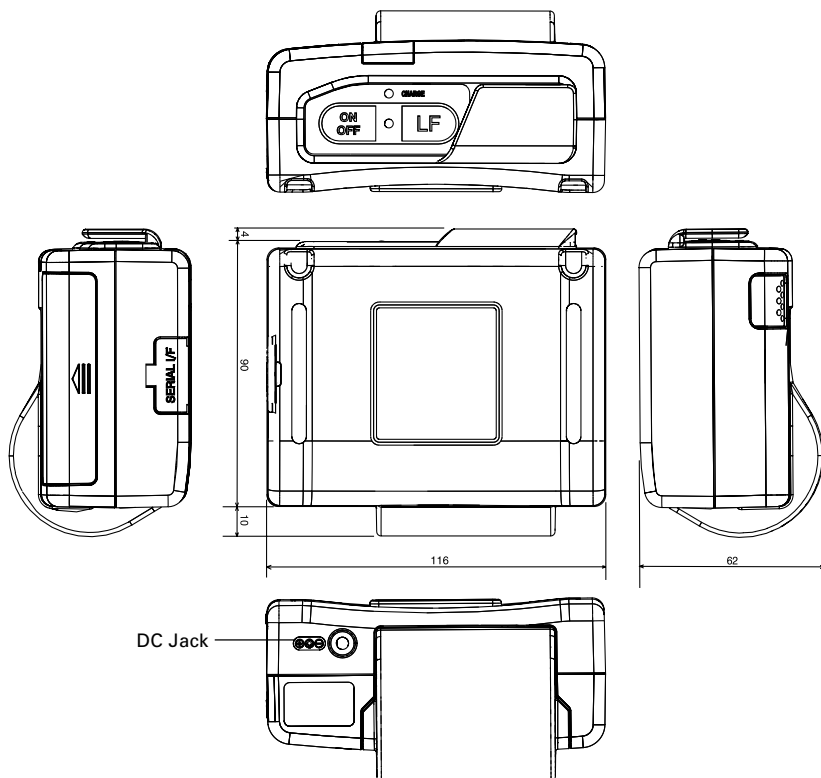

4. OPERATION

4.1 Replacing the Paper Roll

Press Cover Open switch (1).

Open Paper Cover (2).

Place the new paper roll as shown on illustration and pull out enough paper to reach the control panel of the printer (3).

Close the Paper Cover.

If data to be printed still exists, press the LF switch to resume printing.

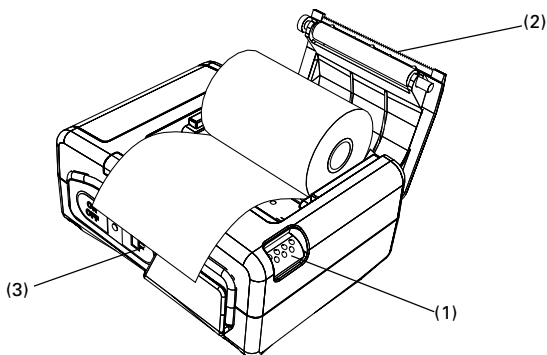

CAUTION!

Be sure to use specified paper rolls!

Make sure that the paper is correctly placed.

If print paper is tilted in one direction or another and does not come out straight from under the cover, open the cover and set the paper roll again.



WARNING

When the paper cover is open, use care not to touch the print head or manual cutter. Burn or cutting hand may result.

4.2 Method of Charging

If any of the following conditions occur, charging the battery is required.

- "Low Battery" is printed.
- The buzzer sounds 3 times.

To charge the battery, plug the connector of the AC adapter to the DC jack of the printer and the AC adapter to the AC outlet. The charge LED lights red. If the LED changes to green, charging has completed.

In case of a trouble while charging the battery, the charge is suspended with blinking of charge LED in red. Try unplugging and plugging AC adapter, then charge should resume and charge LED changes to continue to light red.



CAUTION!

Charge the battery at room temperature (5 - 35°C).

After completion of battery charging, do not try recharging. Battery performance may be deteriorated.

When the battery is used in a cold environment, the operation time may be shortened.

If the operation time is excessively shortened even after full charging, battery life may be assumed.

4.3 Communication by IrDA

Set the infrared port of the device to face straight to the printer's infrared port.

Communication is available in the range of 15° up, down, left, and right.

Avoid blocking between the printer and the device to be connected.

Otherwise, data may not be sent correctly.

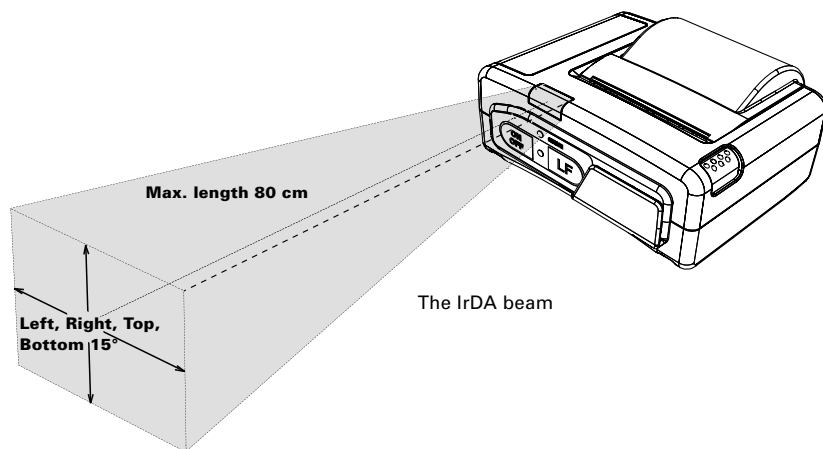

CAUTION!

- Communication in a place exposed to strong light such as direct sunlight and fluorescent lighting may fail in receiving correct data.
- Communication may fail in receiving correct data after leaving the printer unused for a long time in other than storage temperature.
- The range of communication may differ depending on the device used or the environmental condition.
(Communication may be disabled even within the range given in the specification.)

4.4 Communication Via Serial Port (Cable)

For communication with RS-232C, prepare dedicated serial cable. Open the serial port cover and while holding the connector with the wording marked "Push" facing upward, insert the connector into the serial port.

Here, hold the connector with the surface marked "Push" down. Connect the other end of the cable of the cable to the device to be connected.

To disconnect the connector, securely do it while pressing the portion marked "Push".

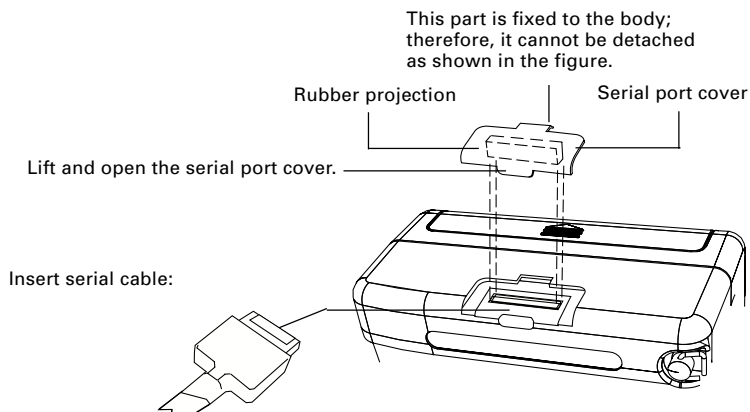

To replace the serial port cover, press in the rubber packing till the cover seats firmly.

CAUTION!

If the cable is connected with Power ON, turn the Power OFF once and then turn the Power ON again to activate the connection with serial cable.

Set the flow control setting of the device to be connected to Xon/Xoff. In case of hardware control (DTR/DSR control), the Power switch may become disabled.

4.5 Reading Mag Stripe Card (Only Model with Built-in Mag Stripe Card Reader)

To read the mag stripe card, it is necessary to send a special command to the printer.

For the command, refer to Command Reference supplied separately.

If mag stripe card command is entered, Power LED lights red.

While the Power LED continues to light for 10 seconds, swipe the card be read during that time.

If 10 seconds has passed or reading is completed, the printer returns to normal mode.

Slide the card with the magstriped surface down to pass the magstripe over the reader part.

When reading has completed, buzzer sounds momentarily and Power LED changes to green.

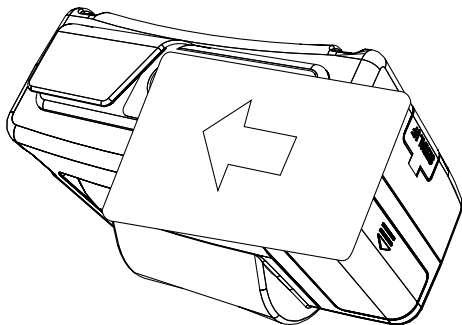

4.6 Removing the Battery Pack

1. Set the printer Power switch to OFF and unplug the AC adapter from printer.
2. Remove the battery cover by (1) pressing the battery cover as shown in the figure, lift it upward.

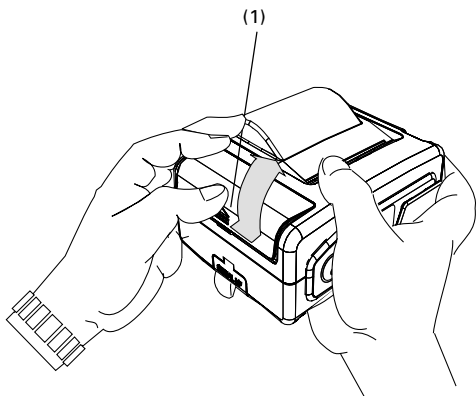

3. Remove cover as shown in the illustration.
4. Remove battery pack from compartment and disconnect battery connector from main unit.

4.7 Installing the Battery Pack

1. Insert the battery connector to the connector of the printer.
2. Insert the battery connecting cable into the opening above the battery connector.
Confirm that the battery connector is seated deeply.
3. Insert the battery into its compartment.
4. Place battery cover back by sliding it from the back of the printer.

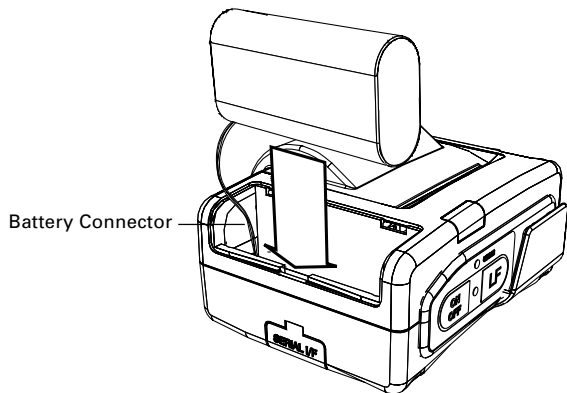

CAUTION!

Be sure to place the battery cover firmly in its position after installing the new battery pack!

5. FUNCTION

5.1 Auto Power OFF

Power is automatically cut off after a specified period of time, during which no command is sent to the printer and the LF switch has not been pressed.

The default setting of this time duration is 10 minutes, however, the period can be custom set by the user with a special command to the printer. (see Command Reference List)

The behavior of the printer at the operation of Auto Power OFF is the same as that when power is turned OFF by the Power switch.

5.2 Interface Selection

The interface is automatically selected depending on the presence or absence of connection to the serial port with a serial cable connector.

- At POWER ON, no cable is connected, the IrDA interface is selected.
- At POWER ON, the cable is connected, the Serial interface is selected.



CAUTION!

If cable is connected with printer power ON, selecting IrDA interface remains valid. If you want to use the serial interface, turn the printer power OFF once, connect the serial cable, and then turn the printer power ON again.

5.3 Low Battery Detection

Battery charge level is monitored at Power ON, before paper feeding, and before printing.

When the buzzer sounds three times or “Low Battery” is printed, immediately charge the battery.

5.4 Monitoring the Print Head Overheating

If the temperature exceeds 65°C for some reason, the printer automatically stops printing with Power LED indication of "Error" to protect the print head.

If the head temperature returns to 60°C or below, the printer is ready for printing.

5.5 Self Testing and Internal Settings

- Keep the LF switch pressed down.
- Press the ON/OFF switch down.
- Release the ON/OFF switch.
- Release the LF switch.

Immediately after releasing the LF switch the printer will print out a SELF TEST report.

At the end of the report, density, auto-power off time, head temperature, battery output voltage, communication mode, baud rate (for serial communication) are printed.

The number of marks * in the parentheses aside battery output voltage shows a level of battery charge in 5 steps.

5.6 Print Area

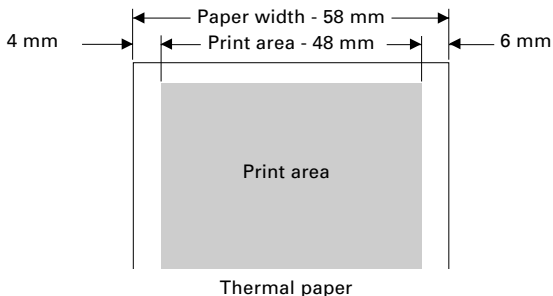

6. LIST OF COMMANDS

1	BEL	Sound the buzzer	*
2	HT	Horizontal tab command	
3	LF	Printing and paper feed	
4	CR	Print command	
5	ESC RS	Sounds the buzzer	*
6	ESC SP	Setting the right space amount of the character	
7	ESC \$	Specifying the absolute positions	
8	ESC %	Selecting user character set	
9	ESC &	Define user characters	
10	ESC !	Collective specifying printing mode	
11	ESC *	Specifying the bit image mode	*
12	ESC +	Switch OFF the printer	*
13	ESC -	Specifying/canceling underline	
14	ESC .	Self test/demo print	*
15	ESC 2	Specifying 1/6-inch line feed rate	
16	ESC 3	Setting line feed rate of minimum pitch	
17	ESC =	Data input control	
18	ESC ?	Mag stripe reader settings	*
19	ESC @	Initializing the printer	
20	ESC D	Setting horizontal tab position	
21	ESC E	Specifying/canceling highlighting	
22	ESC G	ESC G Specifying/canceling double printing	
23	ESC J	Printing and feeding paper	
24	ESC R	Selecting code table	
25	ESC S	Setting Baud rate for the serial port	*
26	ESC T	Printing diagnostic information	*
27	ESC V	Specifying/canceling 90°-right- turned characters	
28	ESC Y	Selecting intensity level	*
29	ESC Z	Returning diagnostic information	*
30	ESC \	Specifying the relative positions	
31	ESC _	Setting the printer in default state	*
32	ESC '	Reading battery voltage and thermal head temperature	*
33	ESC a	Aligning the characters	

34	ESC c5	Enabling/disabling the panel switches	
35	ESC d	Printing and feeding the paper by n lines	
36	ESC v	Transmitting the printer status	
37	ESC x	Setting the time interval for automatic Power OFF	*
38	ESC {	Specifying/canceling the inverted characters	
39	GS)	Setting printer flags	*
40	GS *	Defining the Download Bit Image	
41	GS /	Printing the download, bit image	
42	GS :	Starting/ending macro definition	
43	GS H	Selecting of printing Position of HRI Code	
44	GS L	Setting the left margin	
45	GS W	Setting the print area width	
46	GS ^	Executing the macro	
47	GS a	Enabling/Disabling Automatic Status Back (ABS)	
48	GS f	Selecting the font of HRI code	
49	GS h	Selecting the height of the bar code	
50	GS k	GS k Printing the bar code	
51	GS w	Selecting the horizontal size (scale factor) of bar code	

* indicates a unique command or a non-compatible command.

7. MAINTENANCE AND SERVICE

For information on maintenance and service, please contact your CBM dealer or at the following addresses:

Northern America

CBM America Corporation
Service Center
363 Van Ness Way
Suite 404
Torrance, CA 90501, U.S.A
TEL: +1-310-781-1460
FAX: +1-310-781-9157
E-mail: sales@cbma.com
<http://www.cbma.com/>

Other Areas

Japan CBM Corporation
Information Systems Division
CBM Bldg. 5-68-10, Nakano
Nakano-ku, Tokyo 164-0001,
Japan
TEL: +81-3-5345-7540
FAX: +81-3-5345-7541
E-mail: info-sys@jcbm.co.jp
<http://www.jcbm.co.jp/>

8. APPENDIX

HANDLING BELT CLIP KIT

This kit consists of a belt clip, two screws, and two rubber feet.

8.1 How to Mount Belt Clip

Peel off the cover seal in the square frame at the bottom of the CMP-10 carefully.

Mount the belt clip in the square frame using the two screws supplied. The direction of the belt clip should be as per the drawing below.

Note: Do not use screws without mounting the belt clip. The screws when mounted alone reach too deep and may come in contact with the internal circuit board and cause a failure.

8.2 Mounting Rubber Feet

Confirm that the grooves for the rubber feet are clean and neither dust nor oil is present on the grooves for rubber feet.

Peel off the liner sheet of the adhesive seal for rubber foot and carefully fit the rubber foot to the groove. Press and hold to secure the rubber foot.

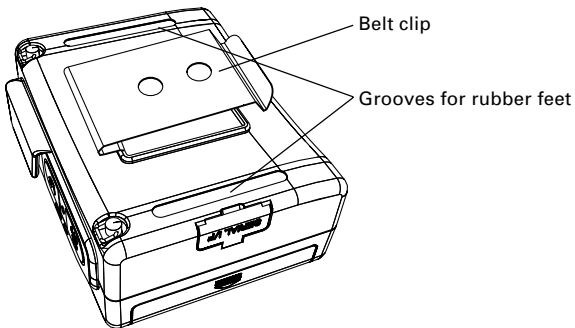

Japan CBM Corporation

Information Systems Division — CBM Bldg., 5-68-10, Nakano, Nakano-ku,
Tokyo 164-0001, Japan
Tel: (+81-3) 5345-7540 Fax: (+81-3) 5345-7541